

Accessory	Application	Publications No.
MOONROOF VISOR P/N 08R01-T2A-100	2014 ACCORD 2 AND 4-DOOR	All 49981
		Issue Date AUG 2013

PARTS LIST

Moonroof visor

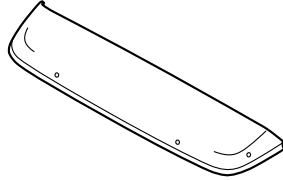

2 Front brackets

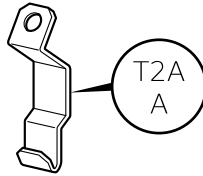

2 Side brackets

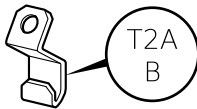

4 Screws



4 Nuts



4 Protective tapes



4 Washers



TOOLS AND SUPPLIES REQUIRED

Phillips screwdriver

10 mm Offset wrench

Ruler

Isopropyl alcohol

Shop towel

Masking tape

Felt-tip pen

The following tool is available through the Honda Tool and Equipment Program. On the iN, click on: Service > Service Bay > Tool and Equipment Program, then enter the number under "Search." Or, call 888-424-6857.

- Torque Screwdriver (T/N CDI401SM)

Illustration of the Moonroof Visor on the Vehicle

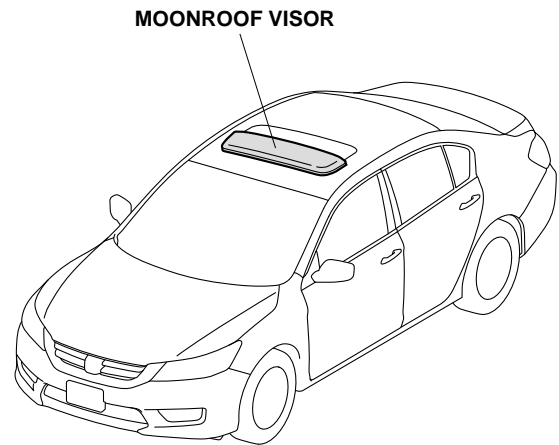

QB21011AG

INSTALLATION

Customer Information: The information in this installation instruction is intended for use only by skilled technicians who have the proper tools, equipment, and training to correctly and safely add equipment to your vehicle. These procedures should not be attempted by “do-it-yourselfers.”

NOTE:

- Install the protective tape only if the ambient air temperature is 15°C (60°F) or above.
- To allow the adhesive to cure, do not wash the vehicle for 24 hours. Please advise your customer.

1. Clean and wax the area to be covered with a high-quality paste wax.

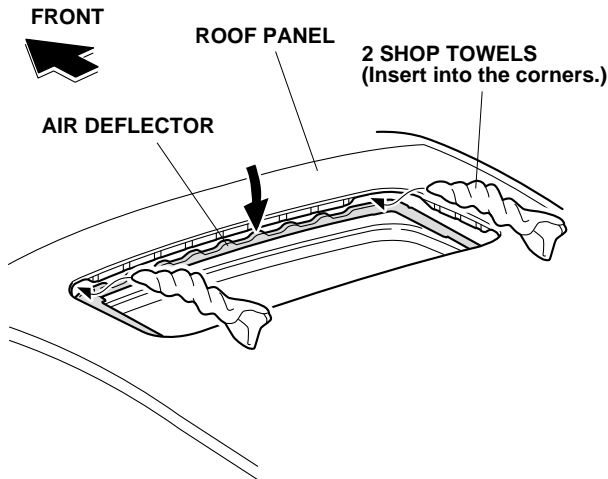

QB21012AG

2. Open the moonroof. Roll up two shop towels, and insert them between the roof panel and air deflector to lower the air deflector. Take care not to damage the air deflector.

3. At the right front corner of the moonroof opening, locate the indentation in the moonroof opening. Measure 40 mm (1.6 in.) toward the front of the vehicle, and make a mark on the roof panel. Measure and mark the left side of the moonroof opening the same way.

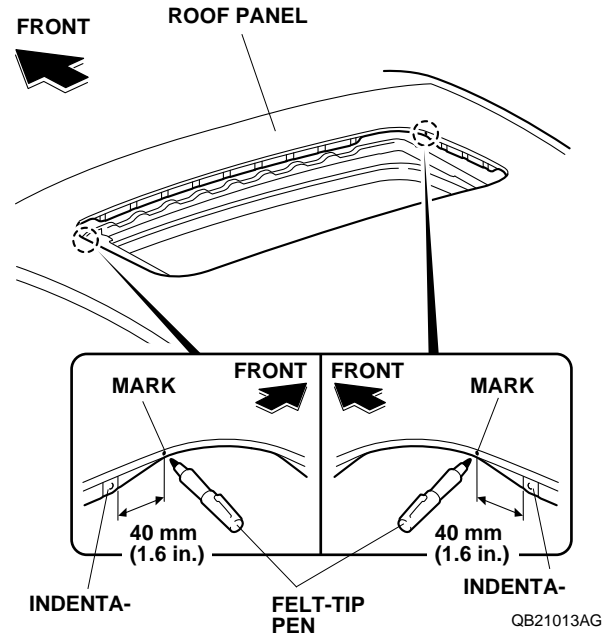

- Using isopropyl alcohol on a shop towel, clean the roof area and the inside edge of the moonroof opening. Starting at the mark you made, clean about 2 inches toward the front of the opening but don't wipe off the mark.

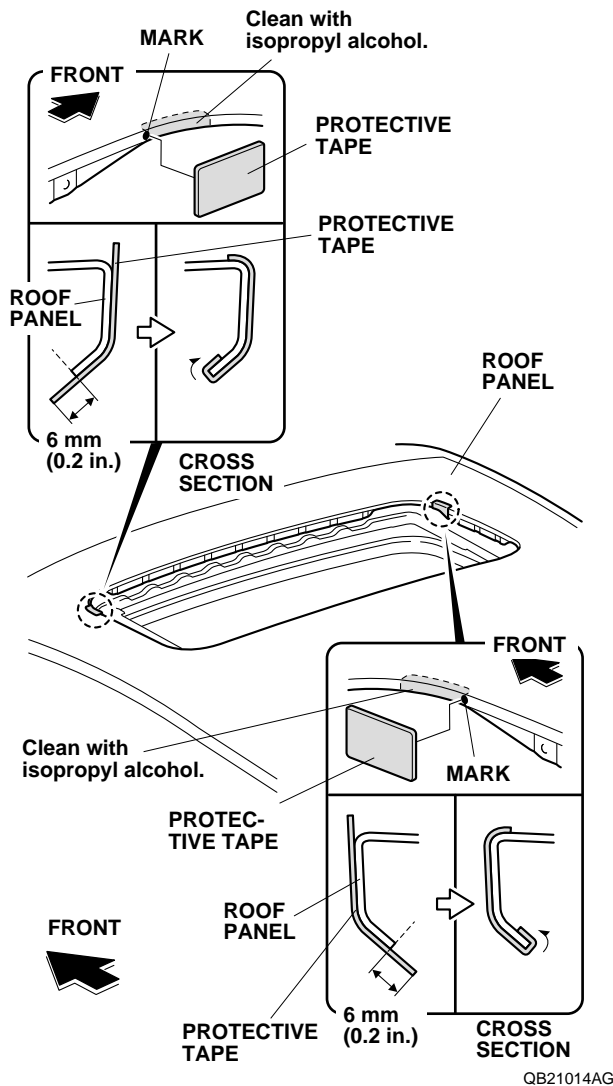

- Remove the adhesive backing from one protective tape, and align the tape with the mark you made on the right side in step 3. Wrap the bottom of the protective tape 6 mm (0.2 in.) around the bottom lip of the moonroof opening as shown. Then wrap the tape around the top of the roof panel.
- Remove the mark you made using isopropyl alcohol on a shop towel.
- Repeat steps 4 through 6 to install the protective tape on the left side of the moonroof opening.

- Locate the second indentation in from the right side on the front of the moonroof opening as shown. Using isopropyl alcohol on a shop towel, clean the roof area where the protective tape will attach.

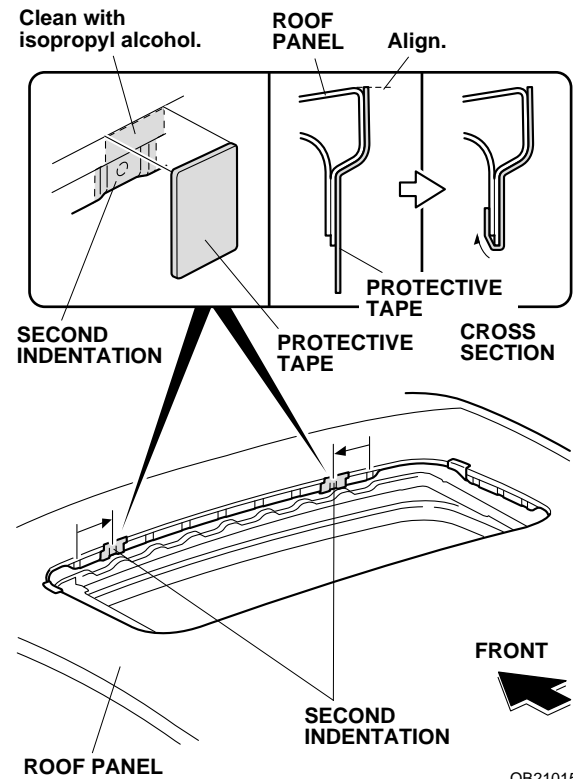

- Remove the adhesive backing from one protective tape. Starting at the top edge, install the protective tape at the second indentation.
- Repeat steps 8 and 9 to install a protective tape on the left side of the moonroof opening.

- Place the two side brackets into position over the protective tape, and tape them in place with masking tape.

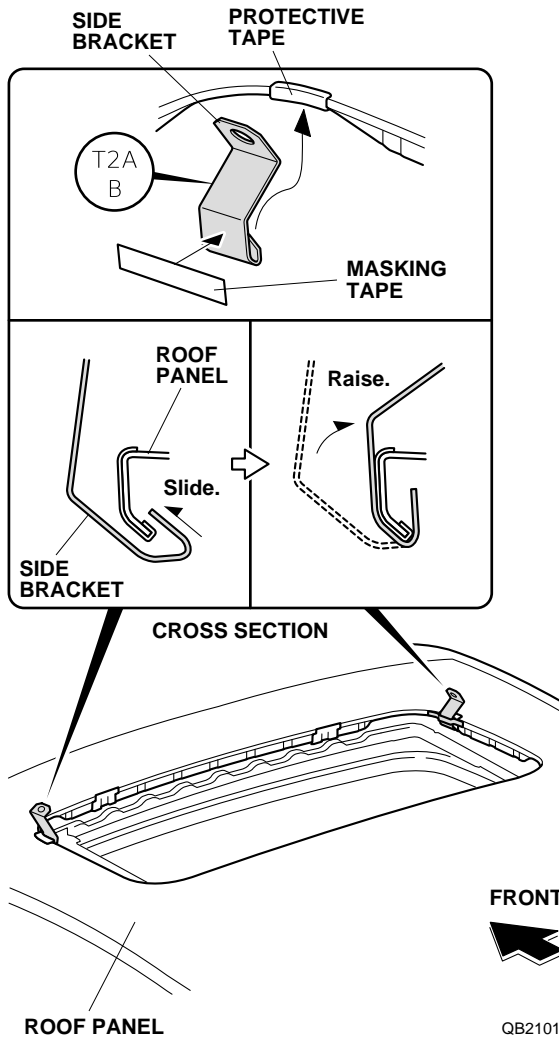

- Place one front bracket into position over the protective tape, and align the lower portion of the front bracket with the indentation in the roof panel. Tape it into position with masking tape.

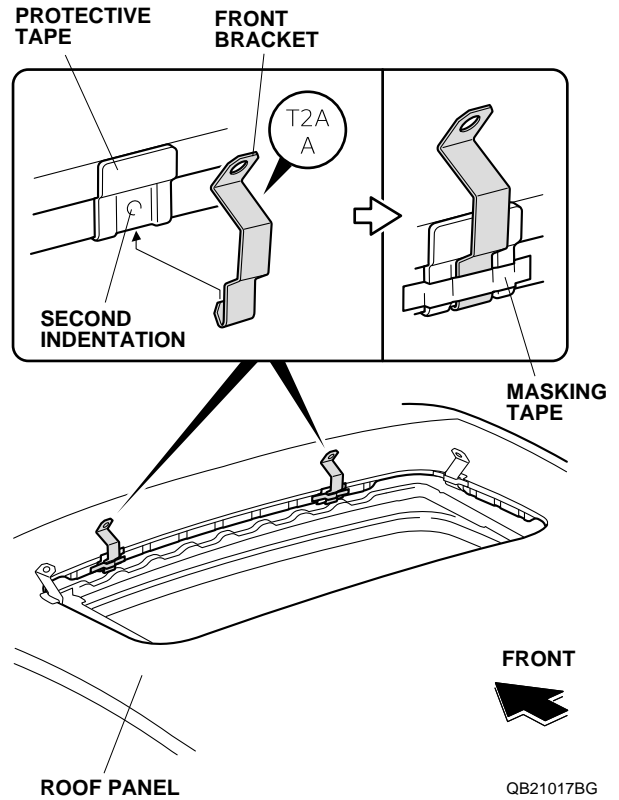

- Install and tape the other front bracket to the moonroof opening the same way.

14. Get the moonroof visor, and check that the rubber molding is not come off from the visor. Set the moonroof visor on the vehicle roof in front of the moonroof opening, and adjust its position so the holes in the visor are aligned with the holes in the front brackets. Loosely install the moonroof visor to the front brackets with two screws, two washers, and two nuts. Remove the masking tape from the front brackets.

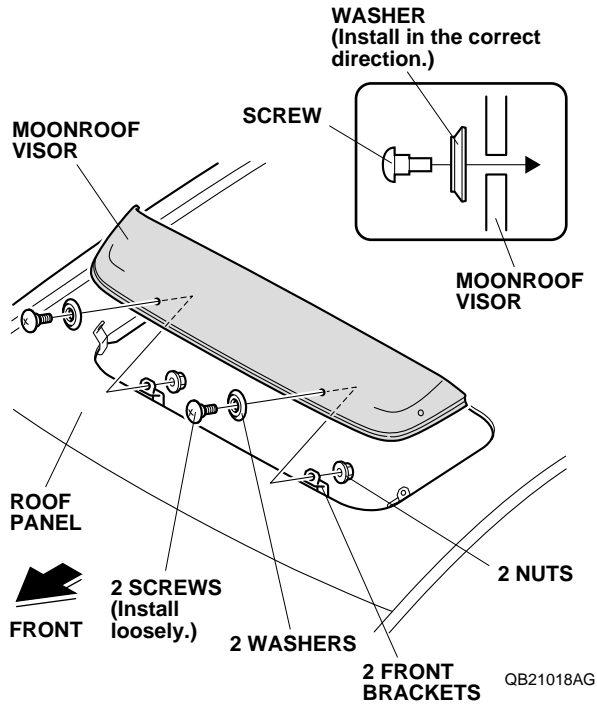

15. Loosely install the moonroof visor to the side brackets with two screws, two washers, and two nuts. Remove the masking tape from the side brackets.

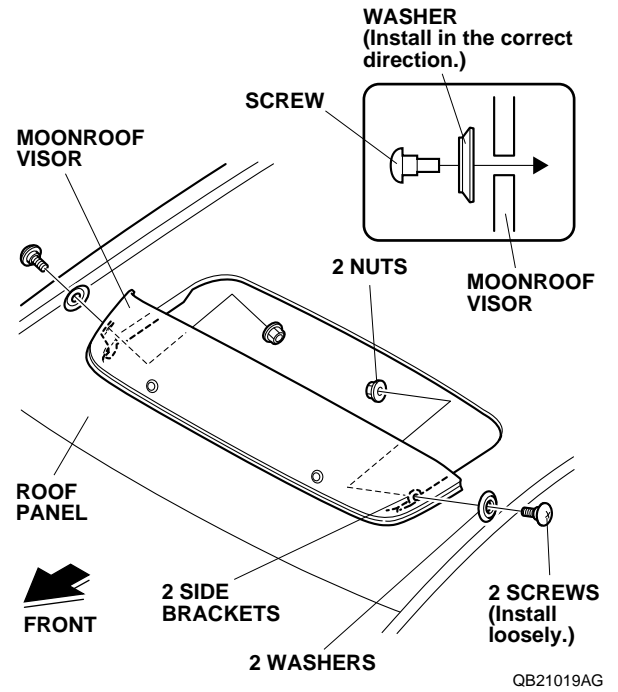

16. Position the moonroof visor with equal spacing in the front and on the sides. Check that the rubber molding is not twisted or rolled under the visor.

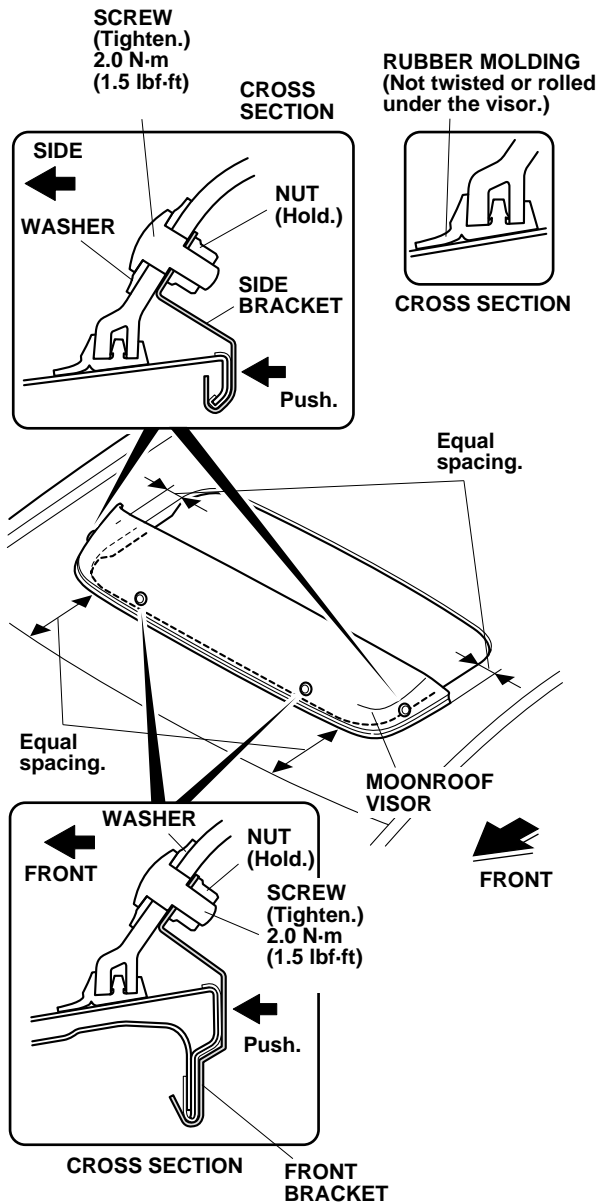

17. Tighten the two screws on the side of the opening first, then tighten the two screws on the front. Apply pressure so that there is no gap between the brackets and the roof panel. Torque the screws to 2.0 N-m (1.5 lbf-ft).

18. Remove the IMPORTANT INFORMATION label and the shop towels.

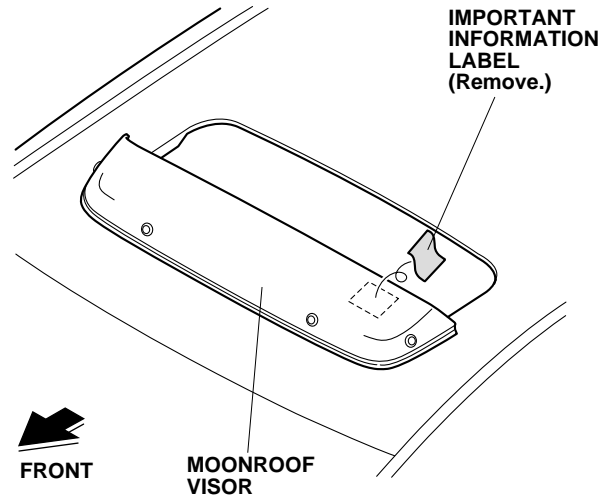

QB21021AG

CARE OF THE MOONROOF VISOR

- To avoid damaging the surface, never use ammonia-based cleaners or solvents to clean the moonroof visor.
- Clean with a solution of mild dishwashing soap and water using a soft cloth or chamois.
- To remove fine scratches and restore the original luster, use Meguiar's Mirror Glaze plastic cleaner and polish or an equivalent high-quality plastic cleaner.